

# MS3010

Mariner Kit for use with HP Z400 Workstation  
(Desktop configuration)



The HP Z400 Workstation is marine type-approved by all of the major international marine Classification Societies when it is installed in conjunction with our Mariner Kit MS3010.

The MS3010 Mariner Kit affords protection against the effects of vibration and shock experienced in the offshore marine environment and has been type-tested against IACS Unified Requirement E10 and the relevant sections of IEC60945 (see below right for test details).

This type-approved combination of hardware and Mariner Kit can be used as the platform for your critical navigation, control, loading and general purpose applications (please check individual type-approval certificates for any restrictions).

**“Steer the right course  
with Mariner Systems”**



## WHAT IS SO SPECIAL ABOUT THE HP Z400 WORKSTATION?

- ◆ With its revolutionary new architecture and power that will redefine multi-tasking, the Z400 helps you accomplish more with every minute of your time and every dollar of your investment
- ◆ The Z400 brings together and optimizes the latest processors, memory, graphics and storage technologies
- ◆ A smart new chassis with quiet acoustics
- ◆ Minimize power and cooling costs with ENERGY STAR® qualified systems featuring 85% efficient power supplies and an HP-developed energy-saving feature that helps lower power consumption in off mode
- ◆ Converts between minitower and desktop configurations
- ◆ Tool-less chassis and uncluttered internal design simplify access for easier upgrades and repairs
- ◆ Built around the Intel® X58 Express chipset and the latest Intel® Xeon® processors
- ◆ Two full-height PCI Express Gen2 x16 slots; One full-height PCI Express Gen2 x8 mechanical / x4 electrical slot; One full-height PCI Express Gen1 x8 mechanical / x4 electrical slot; Two full-height PCI slots
- ◆ Two front, six rear and four internal USB 2.0 ports
- ◆ Worldwide product availability and HP Global Services helps keep corporate costs low and provide consistency across regions and technologies
- ◆ Three-year limited warranty on parts and labour as standard

This Mariner system is type-tested against the consolidated, 'worst-case' requirements of all the major international marine Classification Societies:

### ABS, BV, CCS, DNV, GL, KR, LR, NKK, PRS, RINA

Type-tests included on the test programme are as follows:

- > Vibration, Shock, Static and Dynamic Inclination
- > Dry & Damp Heat, Low Temperature
- > Acoustic Noise, Compass Safe Distance
- > High Voltage, Power Supply Variation & Power Supply Failure
- > Conducted LF & RF, Electromagnetic Field
- > Radiated & Conducted Emissions, Electrostatic Discharge
- > Insulation Resistance, Burst / Fast Transients
- > Surge Immunity, Access to Dangerous Voltages

# MS3010

## Mariner Kit for use with HP Z400 Workstation (Desktop configuration)

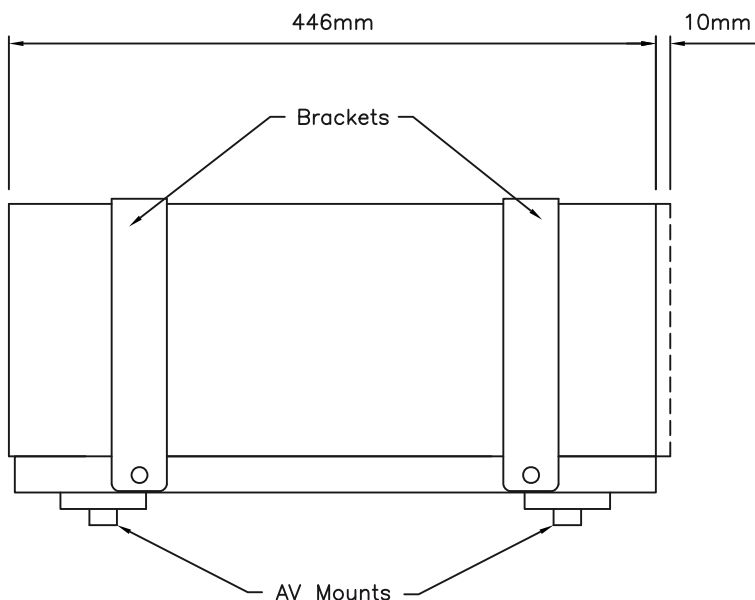
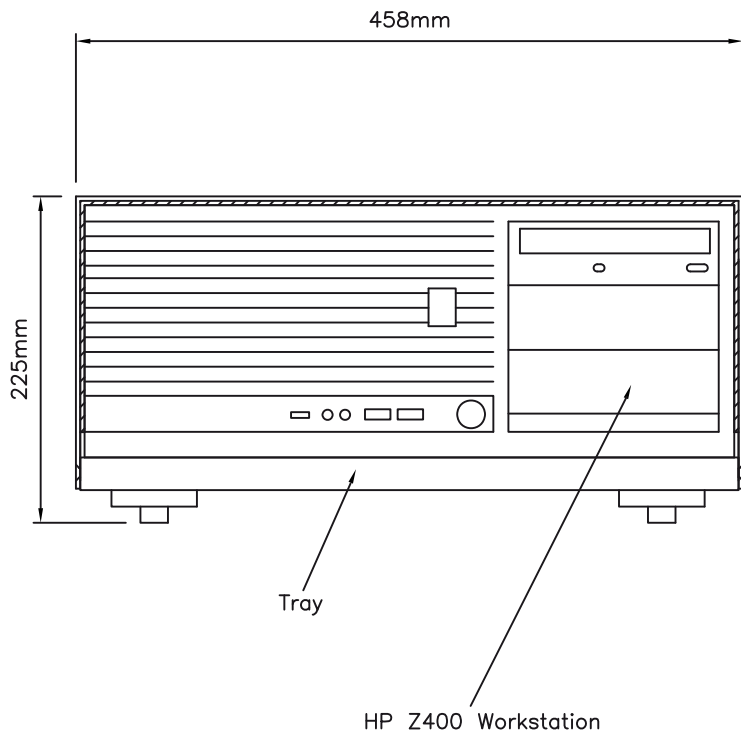

### Mariner Systems (UK) Limited

Oaklands Park • Wokingham • Berkshire • RG41 2FD • United Kingdom  
Telephone: +44 (0) 118 979 6020 • Facsimile: +44 (0) 118 979 6021  
sales@marinersystems.com • www.marinersystems.com

## OPERATING GUIDELINES

Although all our equipment is tested against extreme environmental conditions for the purposes of marine type-approval, installation should take into account the following guidelines:

- > Keep the computer away from excessive moisture, direct moisture and the extremes of heat and cold and, wherever possible, ensure that the unit is within the manufacturer's specified operating/non-operating ranges:

	Operating	Non-Operating
<b>Temperature</b>	+5° to +35°C (+40° to +95°F)	-40° to +60°C (-40° to +140°F)
<b>Humidity</b>	8% to 85% (non-condensing)	8% to 90% (non-condensing)

- > Leave a 15.2 cm (6-inch) clearance on all vented sides of the computer to permit the required airflow
- > Never restrict airflow into the computer by blocking any vents or air intakes
- > Occasionally clean the air vents on the front, back and any other vented side of the computer as lint, dust and other foreign matter can block the vents and limit the airflow
- > If the computer is to be operated within a separate enclosure, intake and exhaust ventilation must be provided on the enclosure, and the same operating guidelines listed above will still apply

By following these guidelines you will maximise the life of your equipment and minimise service costs.

## STATISTICS

<b>Overall Fitted Dimensions</b>	458mm (w) x 225mm (h) x 456mm (d)
<b>Weight (Mariner Kit only)</b>	Approx 3 kg
<b>Weight (including hardware)</b>	Approx 18 kg
<b>Chipset</b>	Intel X58 Express
<b>Available processors</b>	Intel® Xeon® W3503 / W3505 / W3520 / W3540 / W3550 / W3570 (2.40 to 3.20 GHz, 4 to 8 MB L2 cache, 1066 to 1333 MHz FSB) Dual- or Quad-core
<b>Memory</b>	1 to 16 GB DDR3 1333 MHz
<b>Hard Drive(s)</b>	Up to (4) 3.5-inch 7200 rpm SATA drives: 160, 250, 500 GB; Up to (4) 3.5-inch 15k rpm SAS drives: 146 GB
<b>Keyboard</b>	HP Standard (PS/2 or USB)
<b>Mouse</b>	HP 2-Button Optical Scroll (PS/2 or USB)
<b>Network Card</b>	Integrated Broadcom 5764 LAN
<b>Graphics</b>	No integrated graphics; NVIDIA Quadro NVS 290 256MB DH PCI Express; NVIDIA Quadro FX 380 256MB PCI Express; NVIDIA Quadro FX 1800 768MB PCI Express; NVIDIA Quadro FX 4800 1.5GB PCI Express
<b>Optical Storage</b>	HP SATA DVD-ROM; HP SATA SuperMulti LightScribe DVD Writer
<b>Audio</b>	Integrated HD with Realtek ALC262 audio
<b>Operating System</b>	Genuine Windows® Vista Business 32 with downgrade to Windows® XP Professional 32; Genuine Windows® Vista Business 64 with downgrade to Windows® XP Professional 64; Genuine Windows® Vista Business 32; Genuine Windows® Vista Business 64; HP Installer Kit for Linux (includes drivers for both 32-bit and 64-bit OS versions of Red Hat Enterprise Linux WS4 and WS5); Novell Suse SLED 11
<b>Slots</b>	Two full-height PCI Express Gen2 x16 slots; One full-height PCI Express Gen2 x8 mechanical / x4 electrical slot; One full-height PCI Express Gen1 x8 mechanical / x4 electrical slot; Two full-height PCI slots
<b>USB support</b>	12 x USB 2.0 ports - 2 front, 6 rear and 4 internal
<b>Serial Port</b>	1 x internal header (requires optional Serial Port Adapter)

Design and specifications are subject to change without notice. E&OE.

Version 1